



Testing Batteries for Optimal Robot Performance

Isabel Chaput
Michael Most
Robert Most

Team 2619

H.H. Dow High School
Midland, Michigan USA

www.the-charge.com

FIRST Worlds Seminar
April 26, 2018

Introduction

Presenters:

– Isabel Chaput

- Junior at H.H. Dow High School Midland, MI
- Leader of Electrical Team: FRC-2619

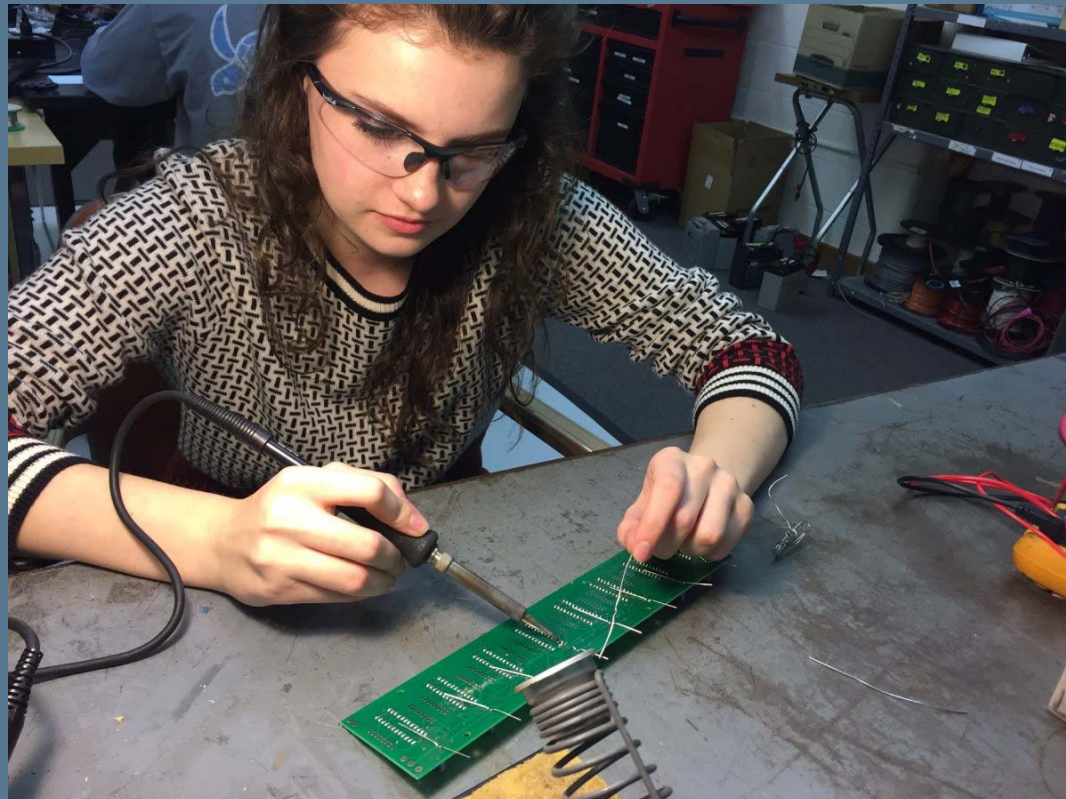

Presenters:

– Michael Most

- Senior at H.H. Dow High School Midland, MI
- One of Three Team Directors: FRC-2619





Introduction

Presenters:

– Robert Most

- Professor/Electrical Engineering Ferris State University
- Mentor: FRC-2619



Presentation Outline

- **Goals & Background**
 - Robert Most
- **History and Research**
 - Michael Most
- **The Battery Test Kiosk Concept**
 - Isabel Chaput
- **Data Analysis and Findings**
 - Michael Most
- **Improvements and Future Goals**
 - Isabel Chaput
- **Conclusions / Q & A**
 - Robert Most

About Team 2619

- H.H. Dow High School, Midland Michigan USA
- Founded in 2007
- Strong STEM Background
- Great Students and Mentors





Team 2619 Electrical Team

- **Provide Students Opportunities in Building Electronic Projects**
- **Some Examples Include:**
 - **Star Ornament Project**
 - **1300 LED Sound Meter**
 - **RADD Scrolling Displays**
 - **Nomad Motor Controller**

Animated Star



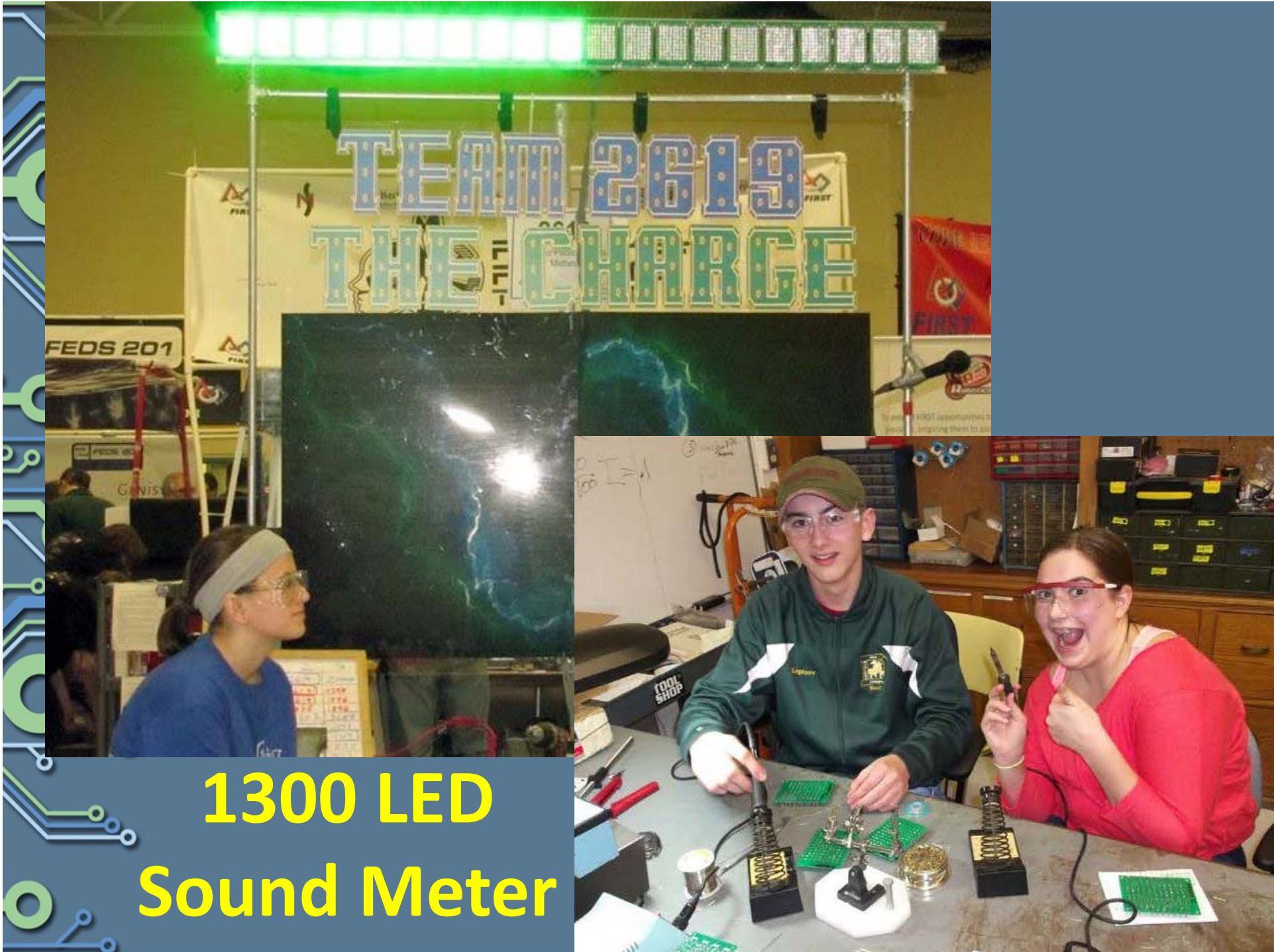

1300 LED Sound Meter



Scrolling LED Signs



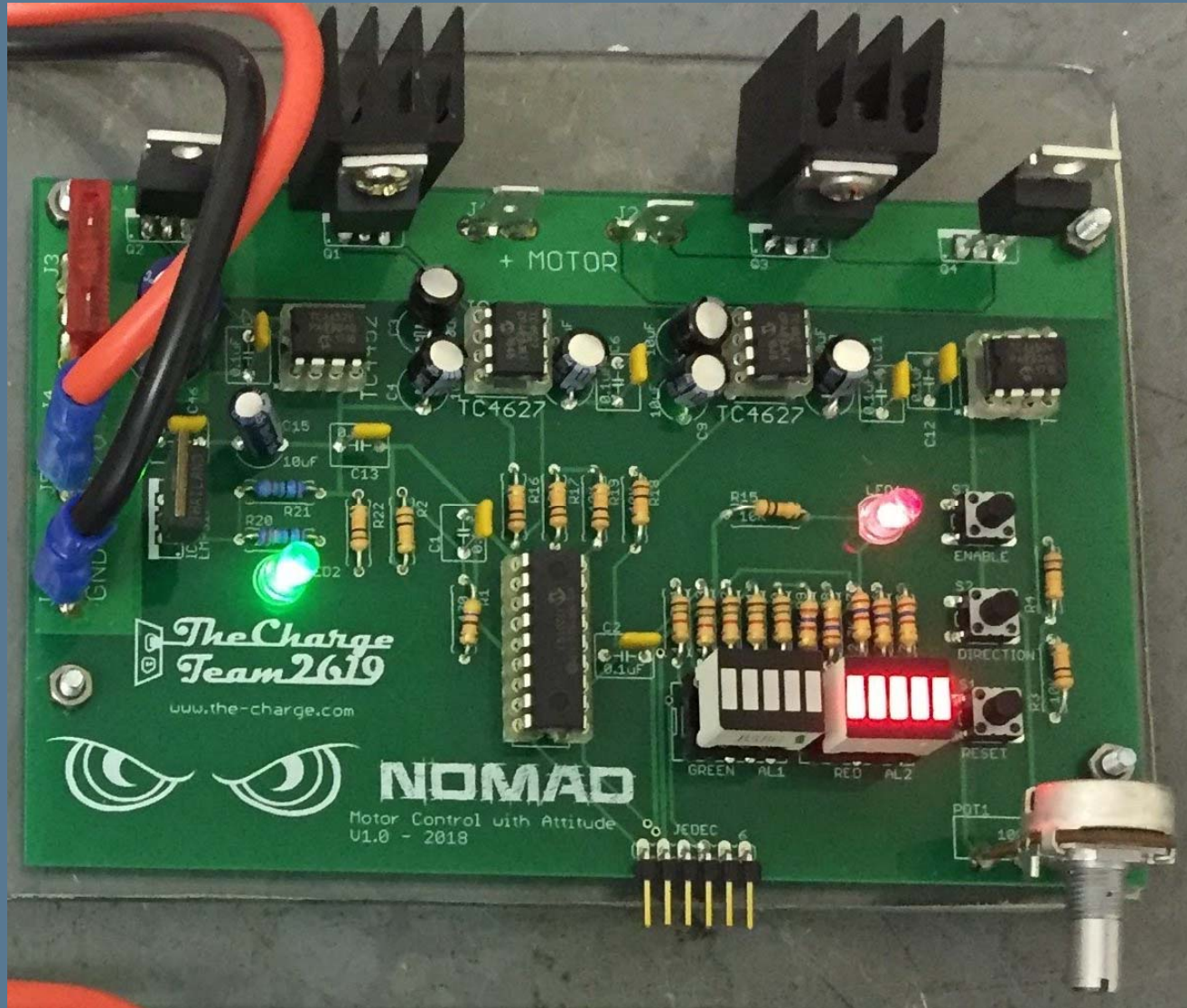

Motor Controller



Importance of Battery Performance

- Poor Robot Functionality
- 2014 “Good” Battery Failure
- Opportunity
 - Research Batteries
 - Understand Performance
- 100% != 😊



Project Goals

- **Understand Battery Performance**
- **Provide Students with Engineering Research**
 - Explore Industry Standards
 - Learn about Battery Technologies
 - Provide a Means for Research / Data Analysis
 - Provide Experience in Technical Writing
 - Create a Workflow for Testing
- **Create a Device that other FRC Teams can build**
- **Create a Kiosk that can be taken to FRC Competitions**



History and Research

Questions That Need to be Addressed:

- What are the Industry Standards in Battery Testing?
- What are the Characteristics of FIRST Robotics Batteries?
- Can we Create a Testing Procedure to Accurately Rank our Batteries?

Teams Accumulate Batteries...



- But which ones are can we rely on when we go to competition??



Battery Testing Standards

We Researched Battery Standards in Industry to Understand How Batteries are Tested:

- SAE J240 – Life Test for Automotive Storage Batteries
- SAE J537 – Automotive Storage Battery Testing
- UL 2054 – Household and Commercial Batteries
- 60254-1 – British Standard for Traction Battery Testing
- IEC 61982-3 Secondary batteries for the Propulsion of Electric Road Vehicles

Characteristics of FIRST Batteries Researched:



- Sealed Lead-Acid Battery Properties
- Internal Resistance Measurement
- Power Output Characteristic
- Effects of Age on Battery Performance



General Procedure to Gauge Performance

- Testing Procedure that...
 - Safe, Accurate, Consistent
 - Key Battery Parameters
 - Ranks Batteries
 - Use the Best Ones

Past Testing Procedure Done Manually

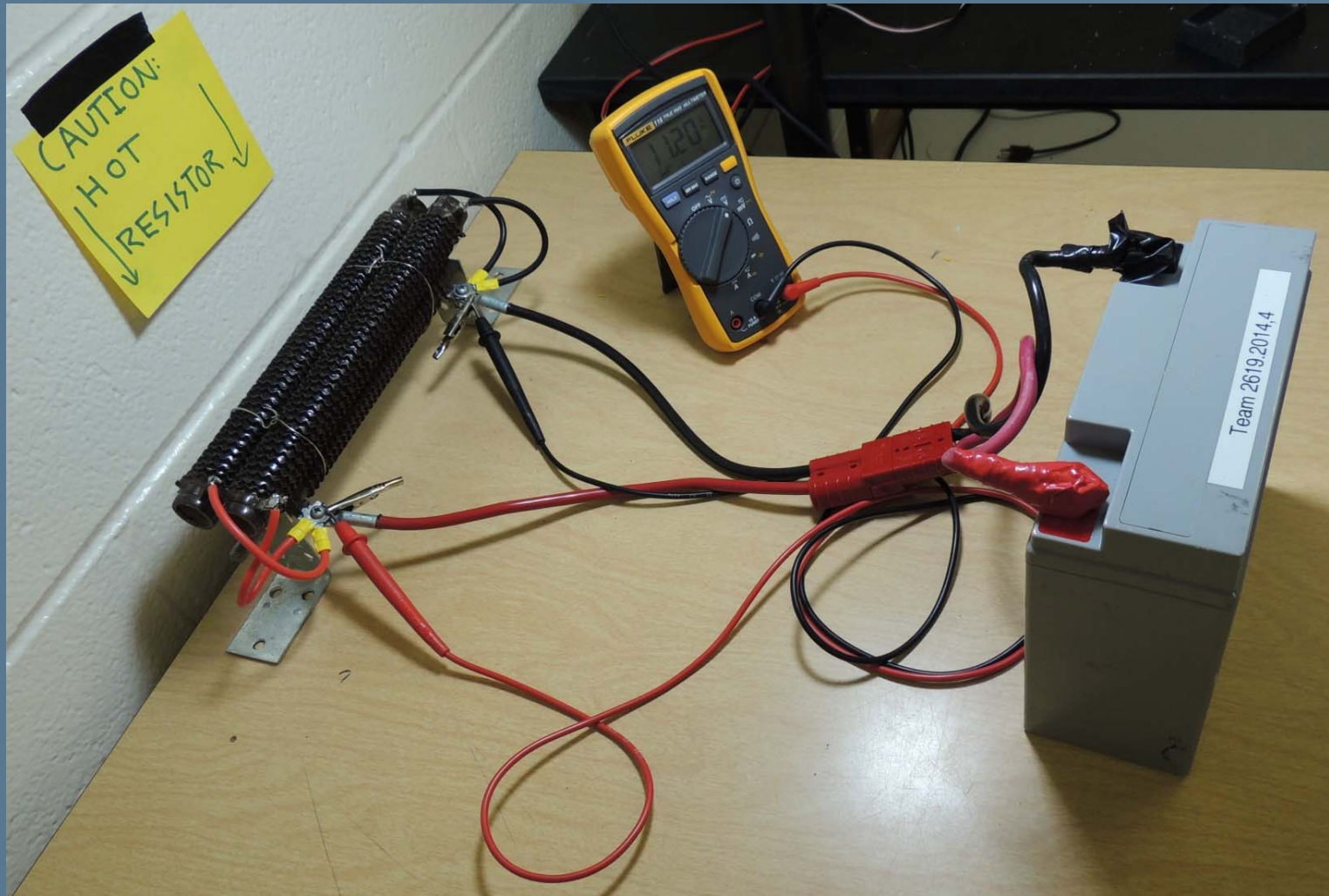

Student Testing a Battery Manually



A “Perfect Battery” Characteristic

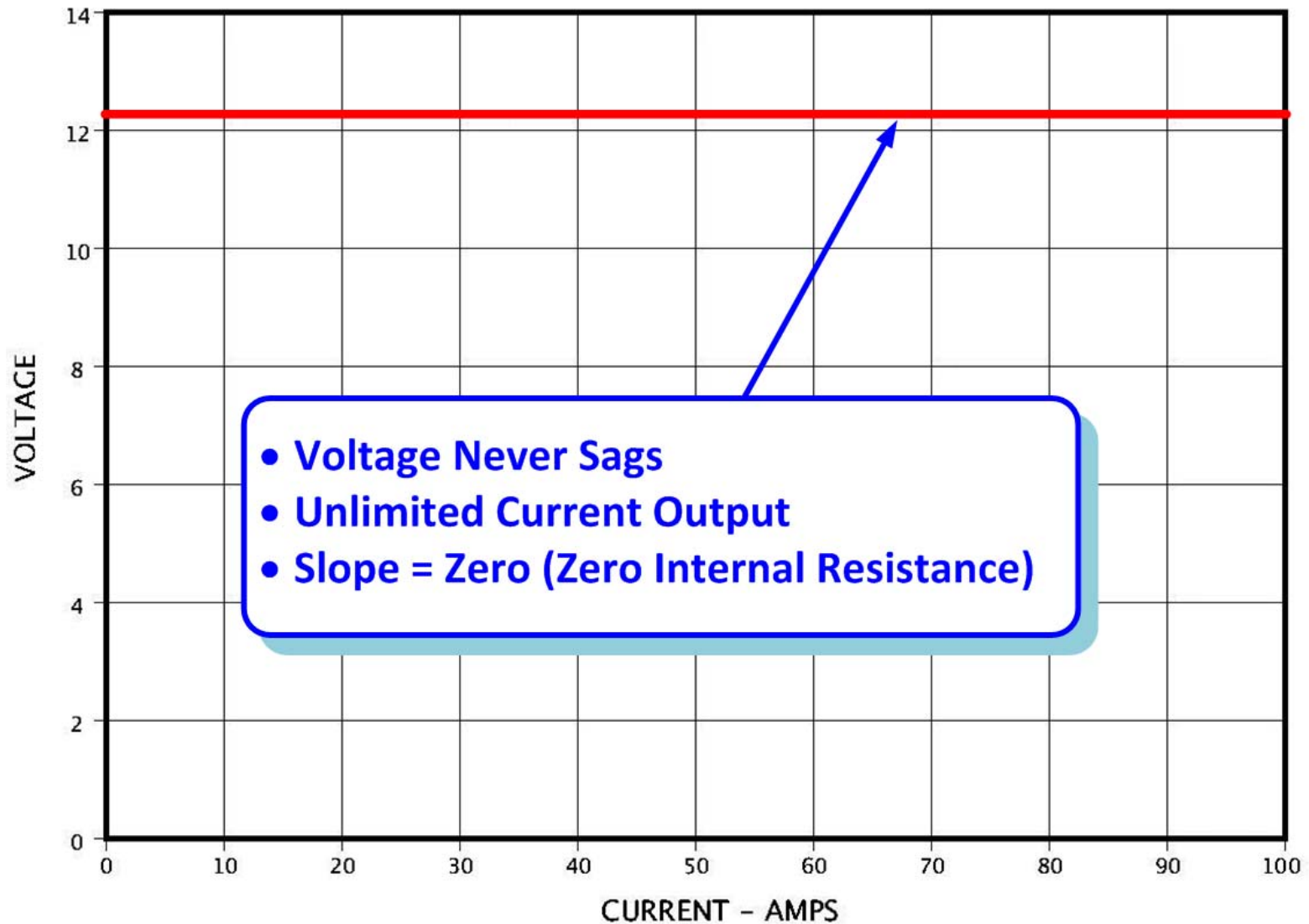



How Would FIRST Batteries Perform on a Characteristic Graph?

- FIRST Batteries are not “Perfect” ...
- Can a Test Platform be Developed to Quickly and Accurately Create a Characteristic Graph?
- What Information Can Such a Graph Provide?

New Battery Test Procedure Flowchart

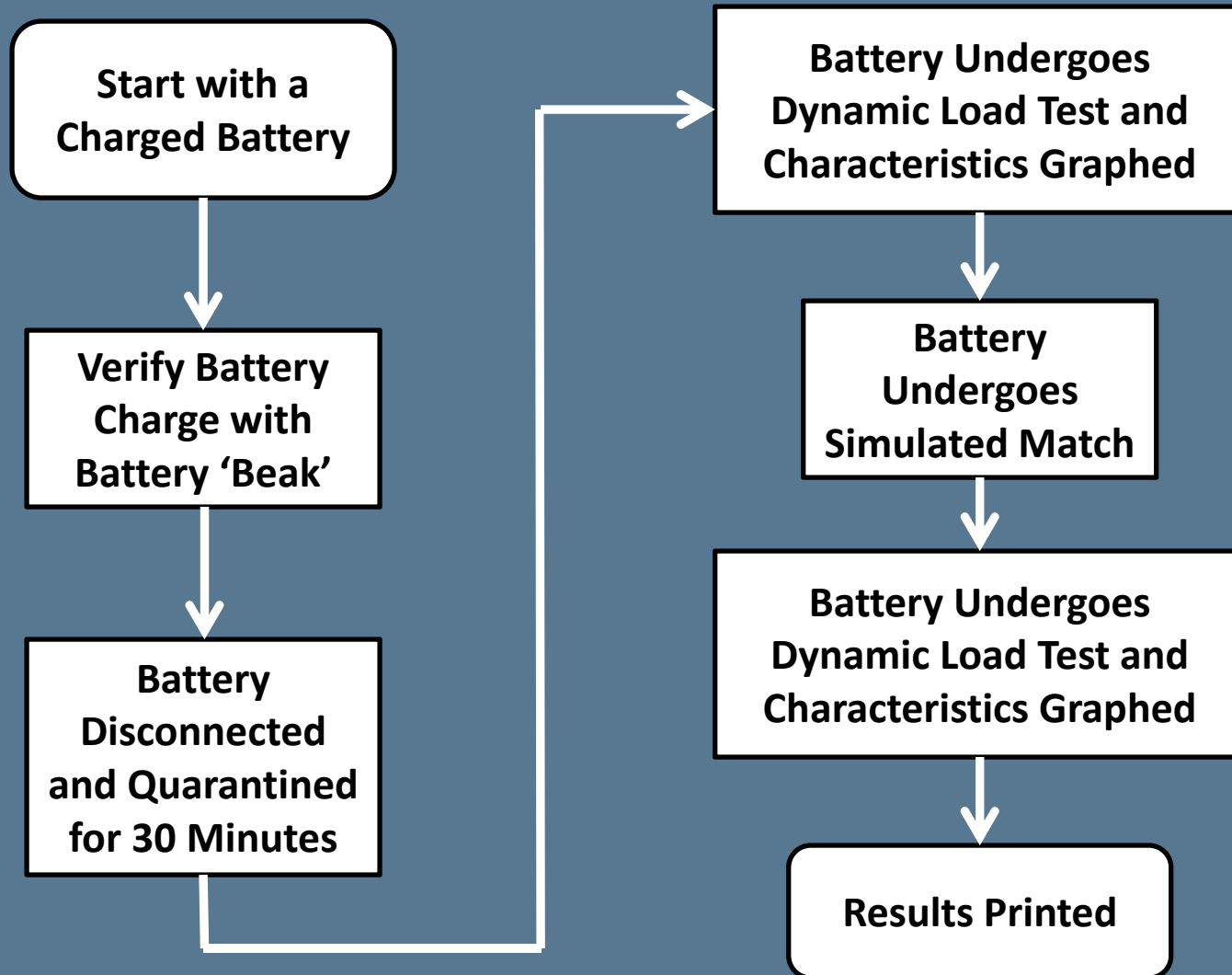

New Testing Procedure In Action!





The Battery Test Kiosk Concept

- **Provide a Rapid Means of Battery Testing**
 - Ease of Hardware & Software Use
- **Automate the Test Procedure**
 - Avoid Introducing Human Errors
 - Provide Consistency in Results
- **Ability to Simulate a Robot Match Through Software**
 - Recipe Based Testing Gathered From a Real Match

Conceptual Block Diagram

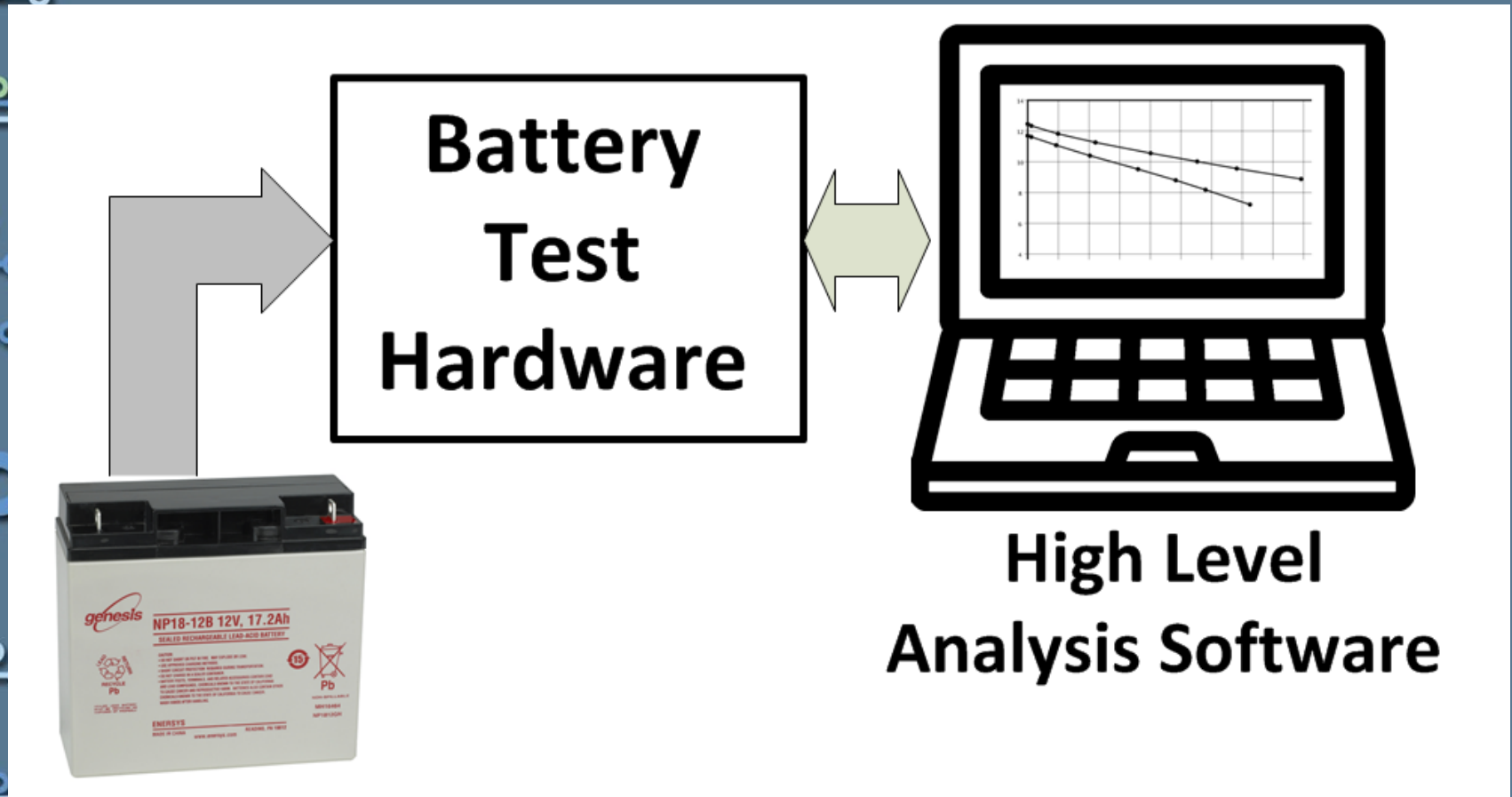



Battery Test Hardware

- A Bank of Power Resistors Can Vary a Load on the Battery Being Tested
- The Power Resistors are Switched On and Off as Directed by a Microcontroller
- The Microcontroller Measures the Battery Voltage and Current and Sends Data to High Level Software on the Host PC

Varying Battery Load

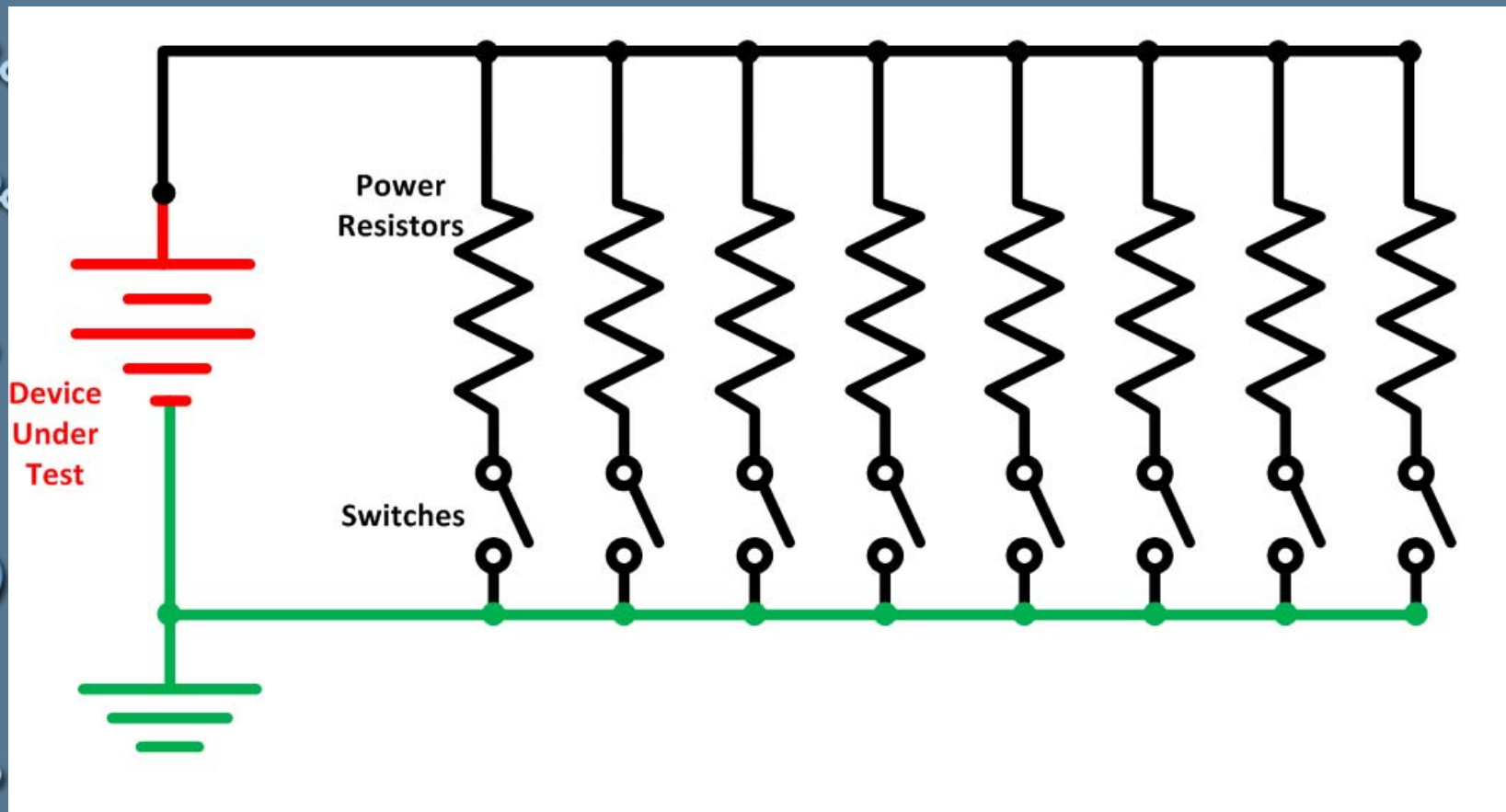

A Varying Load is Achieved by Rapidly Switching Power Resistors According to a Pre-Defined Recipe.



Battery Test Hardware

- The Hardware is Directed by the Host PC Software to Execute Two Functions:
 1. Provide a Varying Load Battery Test Profile.
 - This Test Executes in Less than 10 Seconds
 - Loads the Battery From 0A to a Possible 125A
 - Sends Data to the Host PC for Graphing
 2. Execute a Match Load Simulation.
 - This Test Simulates a Predefined 2 Minute Match Complete with Autonomous and Tele-Operated Modes

Battery Test Hardware Block Diagram

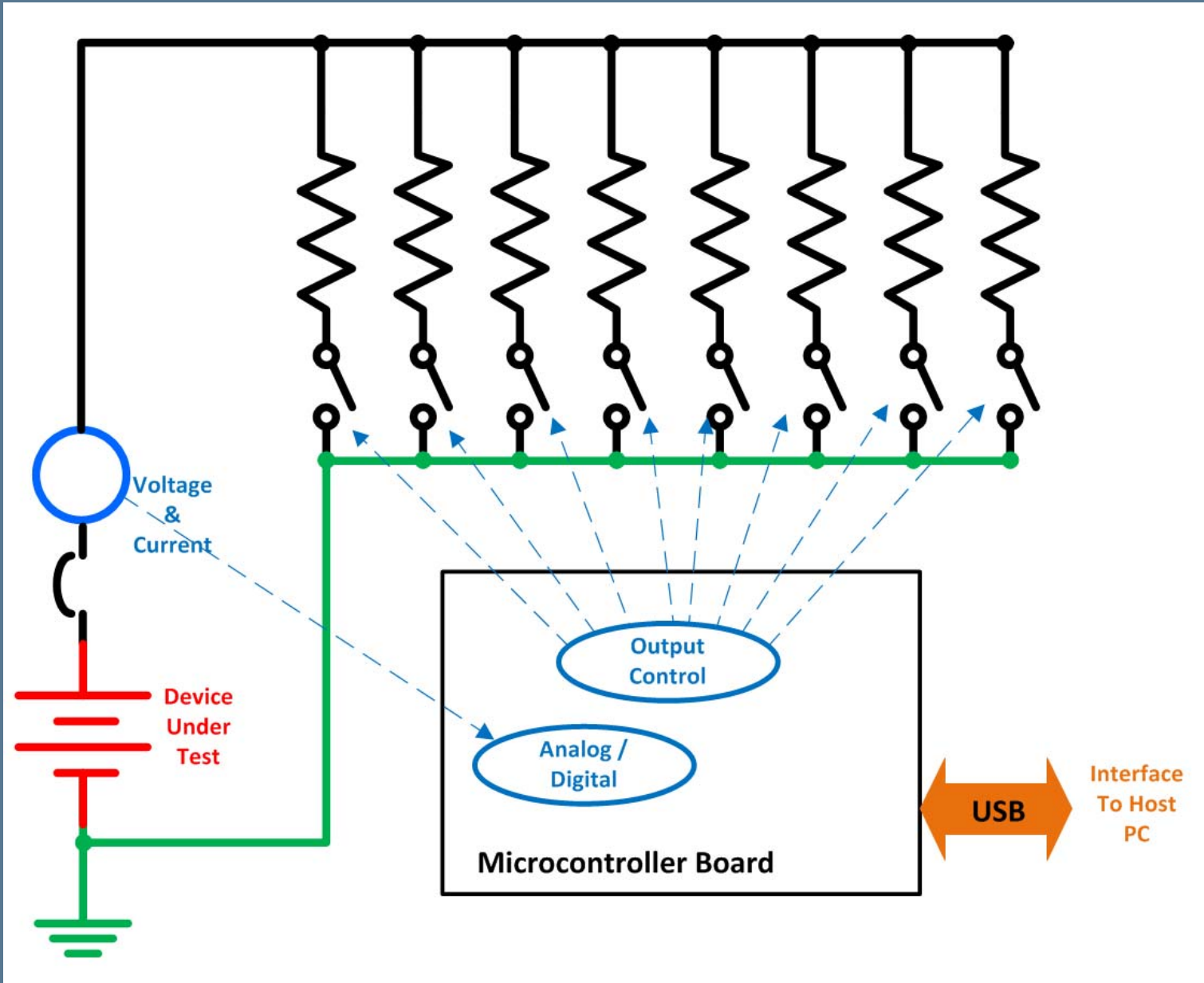



Major Hardware Components

- 120A FIRST Robotics Main Breaker
- Eight power resistors
- Eight High Current Switches (MOSFETs)
- Current Sensor
- 12 Bit Analog to Digital Conversion
- USB Interface to Host PC



Power Supply

Current Sensor

Main Breaker

Load Resistors

Controller Board

USB Interface

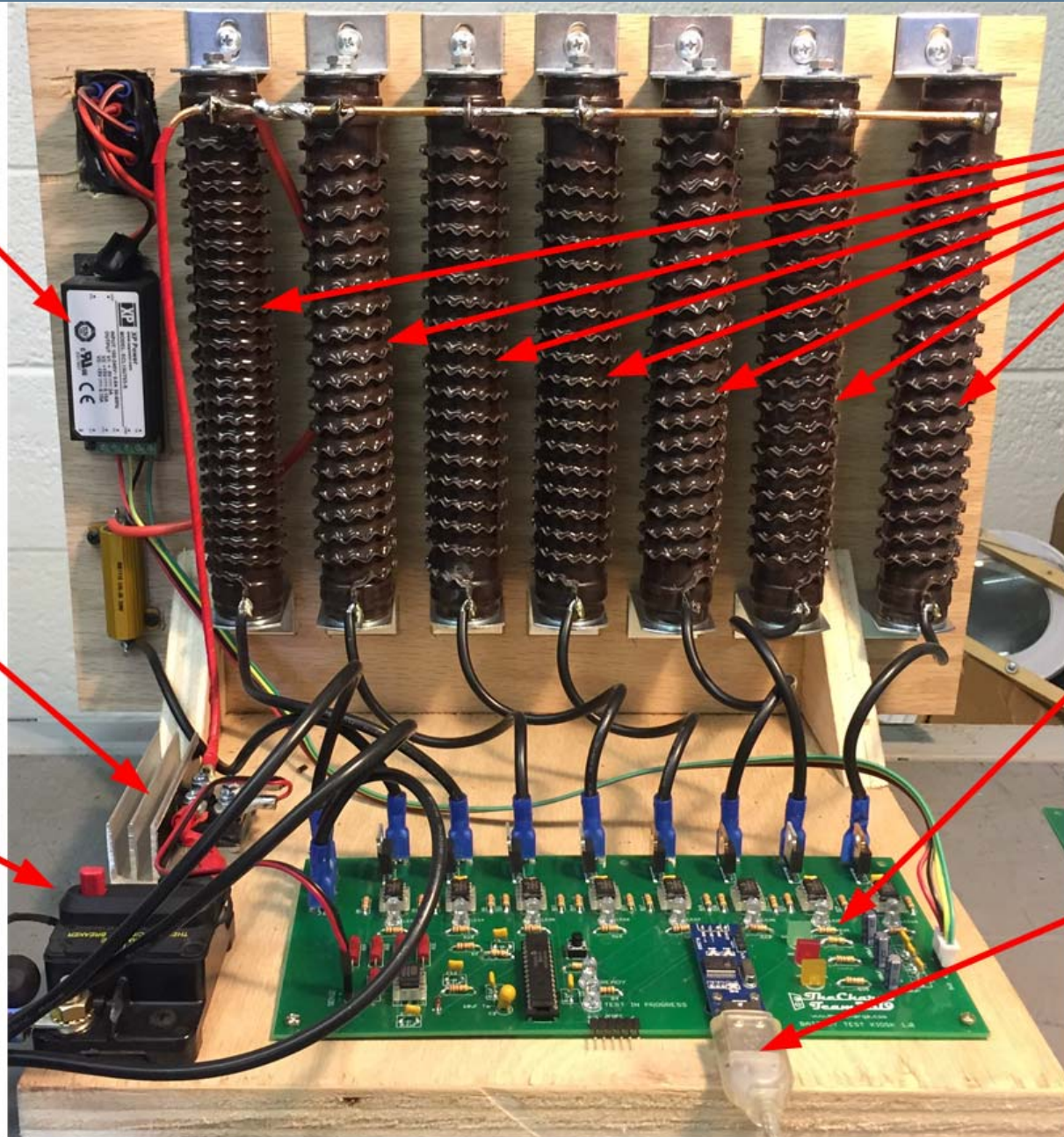

Hardware Top View

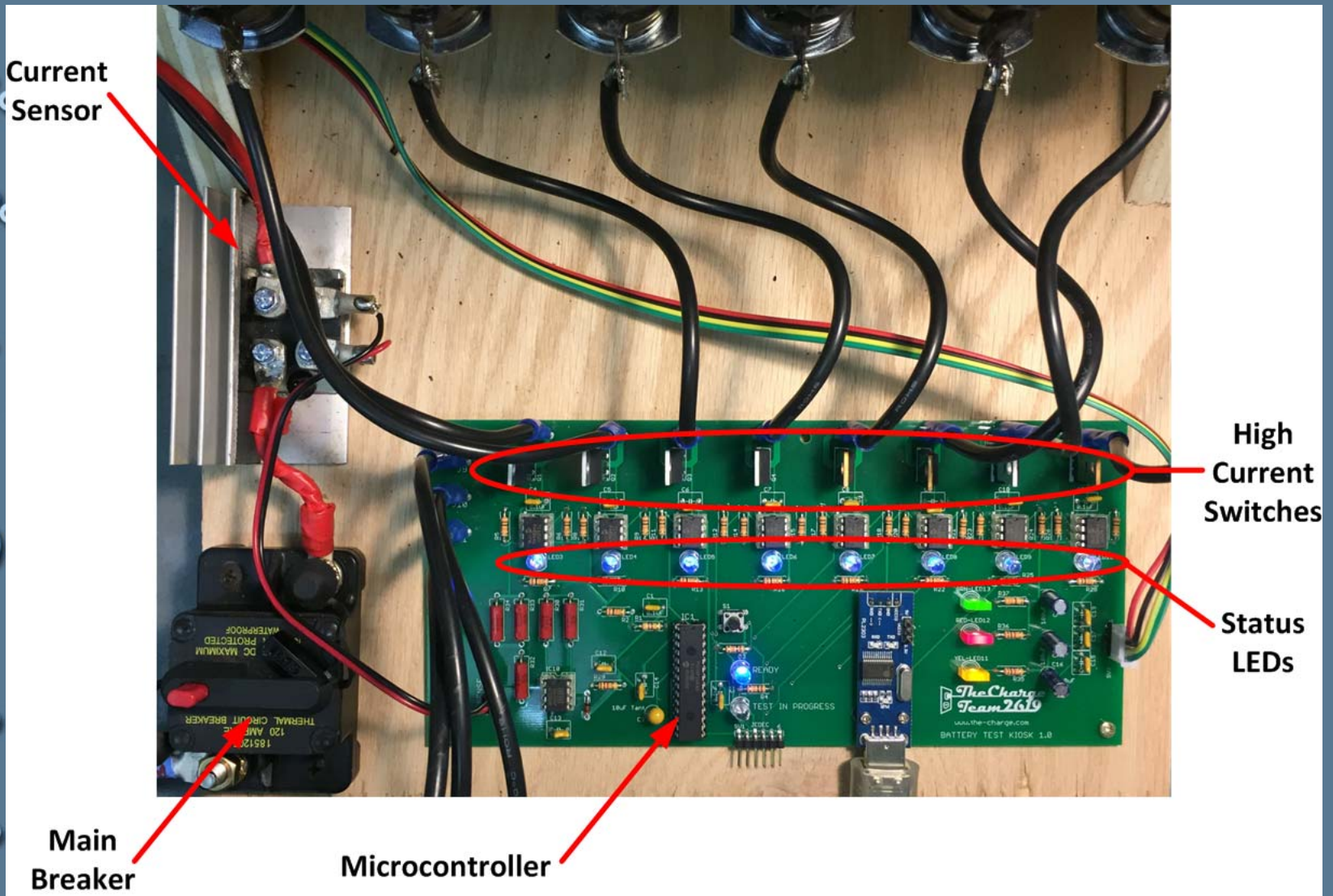

Hardware Controller Board

- Custom Circuit Design
- Use of Standard Industry Parts

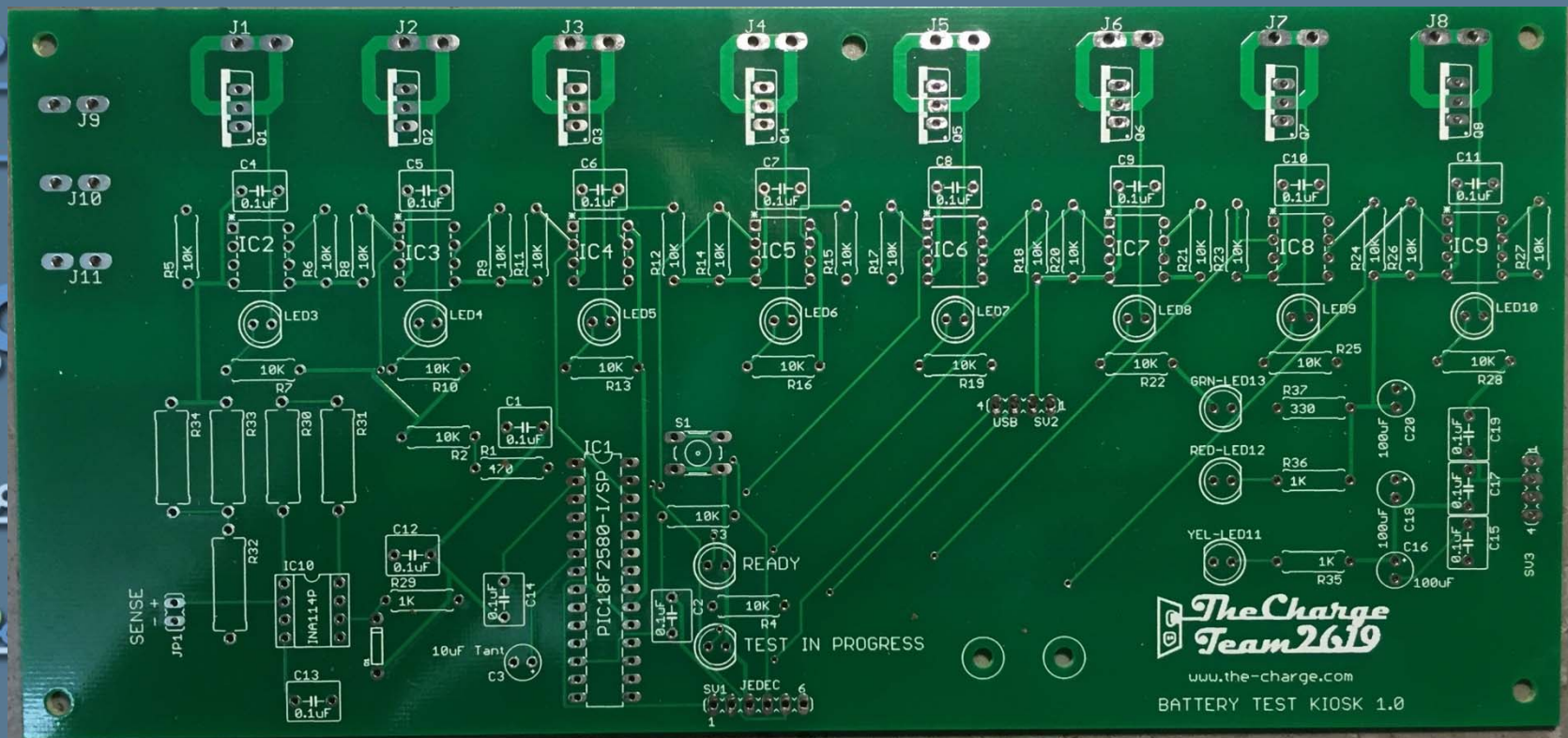

Fully Populated Board

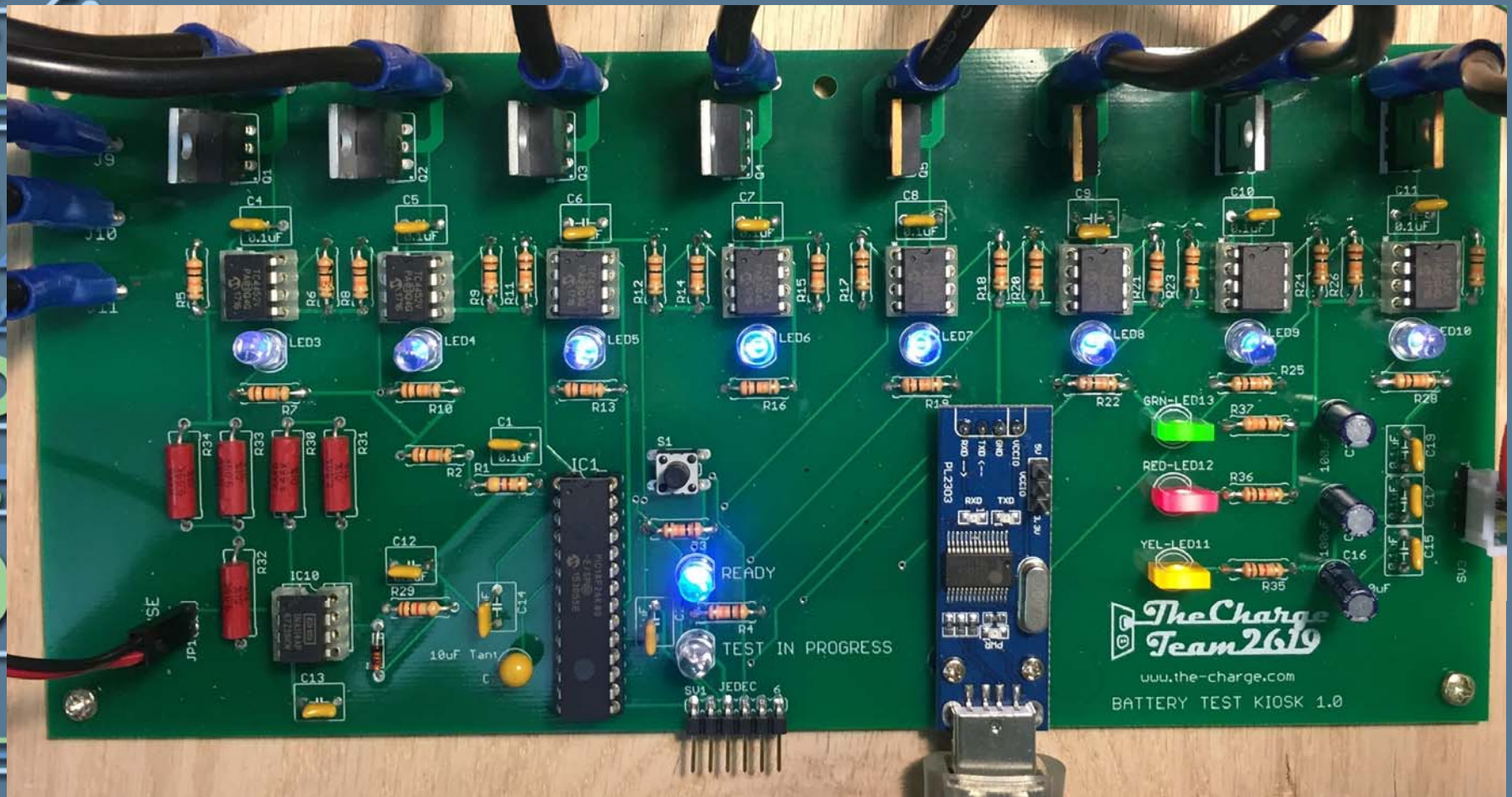

Battery Test Software

- Written in Open-Source Java-Like Language called 'Processing 3.0'
- Developed in the Aesthetics and Computation Group at the MIT Media Lab in 2012
- This Software is Available for Free



Processing 3.0 Environment

Battery_Test_Kiosk_Production_pdf | Processing 3.1.1

File Edit Sketch Debug Tools Help



Battery_Test_Kiosk_Production_pdf

```
133 text("Load #5 Current:", 50,580);
134
135 text("Load #6 Voltage:", 50,620);
136 text("Load #6 Current:", 50,650);
137
138 text("Load #7 Voltage:", 50,690);
139 text("Load #7 Current:", 50,720);
140
141 fill(0,255,0); // color of fill for button
142 stroke(127); // color of lines below
143 strokeWeight(5); // Thickness of line around buttons below
144 rect(50, 100, 200, 50, 100); // Define Button 1 [ start horiz, start vert, width, height, radius on corners ]
145 fill(0); // Color of text to fill as defined below; 0 = black, 255 = white
146 textSize(18);
147 text("Click To Start Test",70, 130); // text + X/Y coordinate of where to start - center is +30 from the rect defined above
148
149 fill(0,255,0); // color of fill for button
150 stroke(127); // color of lines below
151 strokeWeight(5); // Thickness of line around buttons below
152 rect(50, 760, 200, 50, 100); // Define Button 2 [ start horiz, start vert, width, height, radius on corners ]
153 fill(0); // Color of text to fill as defined below; 0 = black, 255 = white
154 textSize(18);
155 text("Match Simulator",76, 792); // text + X/Y coordinate of where to start - center is +30 from the rect defined above
156
157 fill(0,255,0); // color of fill for button
158 stroke(127); // color of lines below
159 strokeWeight(5); // Thickness of line around buttons below
160 rect(1525, 760, 200, 50, 100); // Define Button 3 [ start horiz, start vert, width, height, radius on corners ]
161 fill(0); // Color of text to fill as defined below; 0 = black, 255 = white
162 textSize(18);
163 text("Print Results",1570, 792); // text + X/Y coordinate of where to start - center is +30 from the rect defined above
164
165 myPort = new Serial(this, "COM5", 19200); // Starts the serial communication
166 myPort.bufferUntil('\n'); // Defines up to which character the data from the serial port will be read. The character '\n' or 'New Line'
167 }
```

Video of Test Procedure

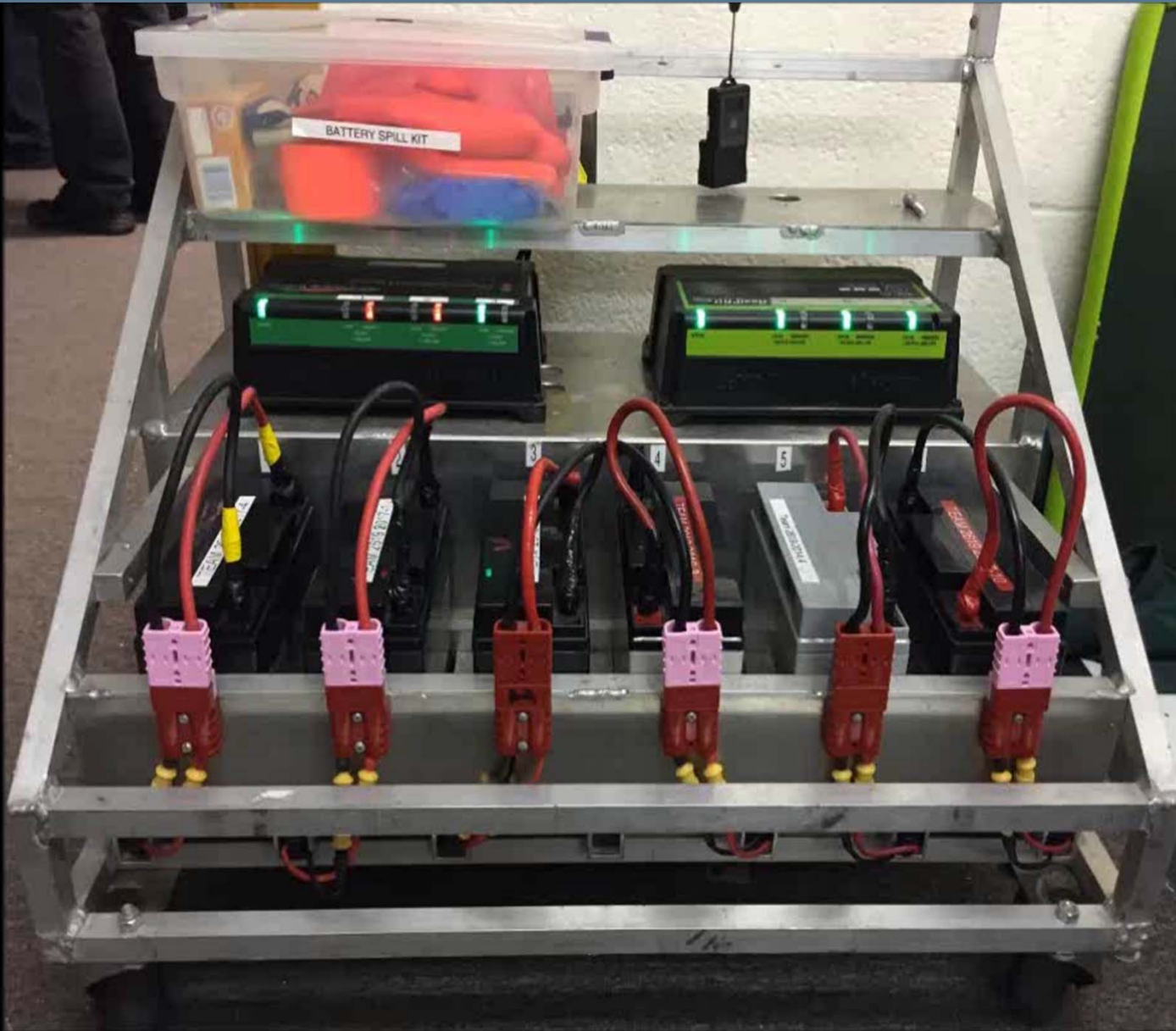



Data Output and Analysis

- Examples of Characterization Graphs
- How Data was Analyzed
- Ranking Criteria
- Data Analysis Graphs

Typical Output After Complete Test

Enter Battery I.D. Information: 2009-1

Click To Start Test

Open Circuit Voltage: 11.68V
Open Circuit Current: 0.00A
Load #1 Voltage: 11.62V
Load #1 Current: 1.23A
Load #2 Voltage: 11.07V
Load #2 Current: 9.36A
Load #3 Voltage: 10.39V
Load #3 Current: 20.36A
Load #4 Voltage: 9.50V
Load #4 Current: 36.03A
Load #5 Voltage: 8.78V
Load #5 Current: 48.34A
Load #6 Voltage: 8.16V
Load #6 Current: 58.05A
Load #7 Voltage: 7.22V
Load #7 Current: 72.50A

Match Simulator

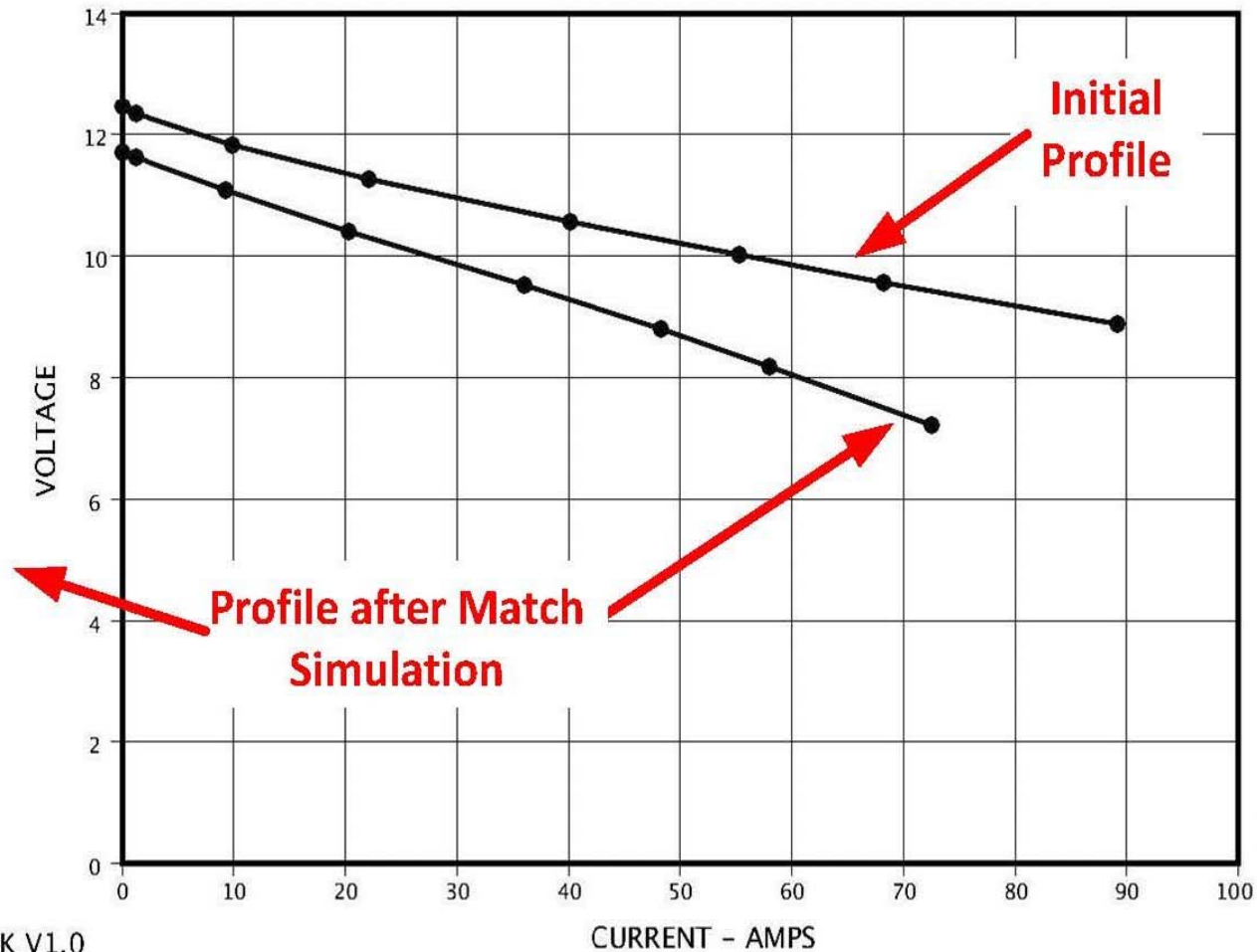

Print Results



How Data was Analyzed

- “Loads” of Information
 - Battery Resiliency through Disparity
 - Slope of Line is the Battery Internal Resistance
 - Slope is Sometimes Non-Linear!
 - Maximum Power Output After Simulation is Easily Determined
- Performance Over Time

Excellent Battery Characteristic Graph

Enter Battery I.D. Information:

[Click To Start Test](#)

Open Circuit Voltage: 12.68V
Open Circuit Current: 0.00A
Load #1 Voltage: 12.66V
Load #1 Current: 1.32A
Load #2 Voltage: 12.41V
Load #2 Current: 10.46A
Load #3 Voltage: 12.11V
Load #3 Current: 23.62A
Load #4 Voltage: 11.68V
Load #4 Current: 44.07A
Load #5 Voltage: 11.32V
Load #5 Current: 62.01A
Load #6 Voltage: 11.00V
Load #6 Current: 77.84A
Load #7 Voltage: 10.52V
Load #7 Current: 104.42A

[Match Simulator](#)

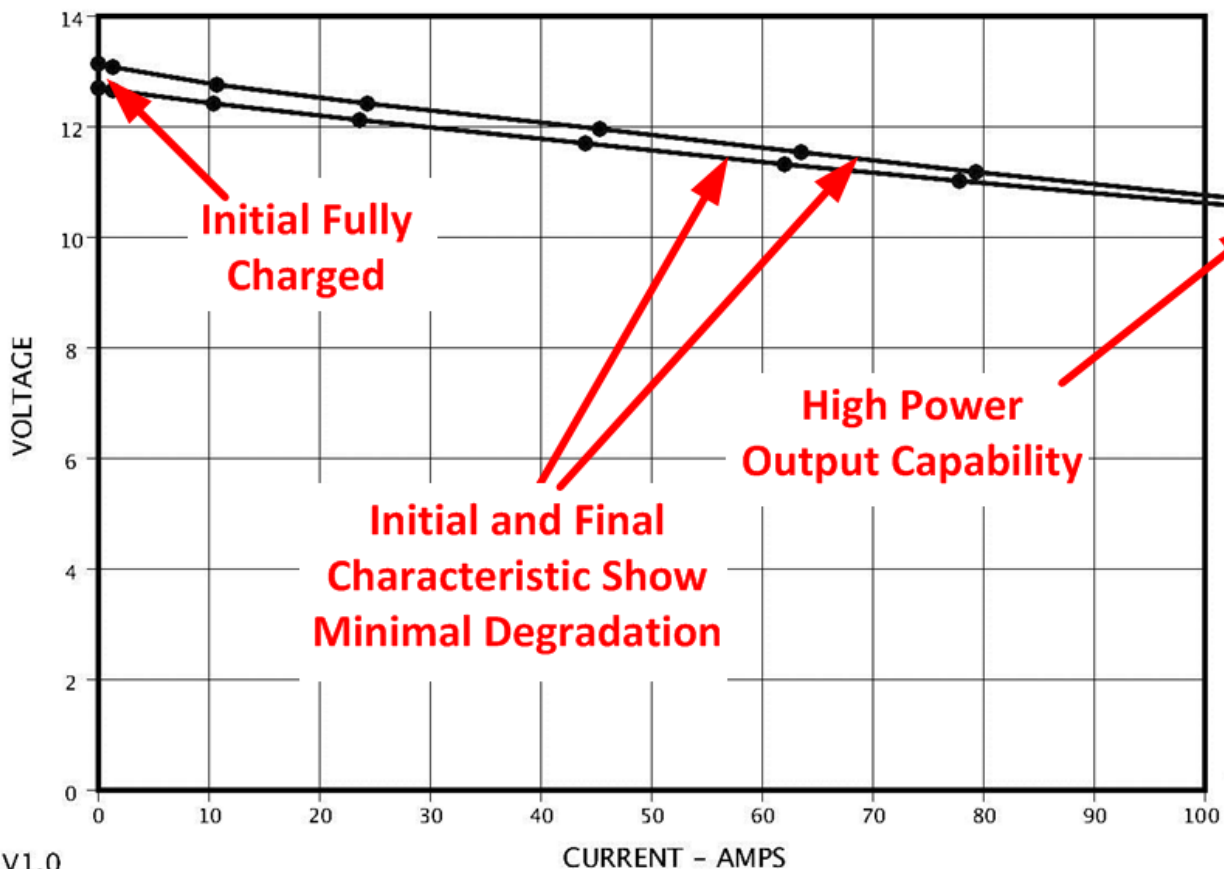

[Print Results](#)

Team 2619 Battery Test KIOSK V1.0

Poor Battery Characteristic Graph

Enter Battery I.D. Information:

[Click To Start Test](#)

Open Circuit Voltage: 10.89V
Open Circuit Current: 0.00A
Load #1 Voltage: 10.47V
Load #1 Current: 1.13A
Load #2 Voltage: 7.97V
Load #2 Current: 6.82A
Load #3 Voltage: 6.10V
Load #3 Current: 12.03A
Load #4 Voltage: 4.49V
Load #4 Current: 17.09A
Load #5 Voltage: 3.60V
Load #5 Current: 19.88A
Load #6 Voltage: 3.02V
Load #6 Current: 21.58A
Load #7 Voltage: 2.35V
Load #7 Current: 23.69A

[Match Simulator](#)

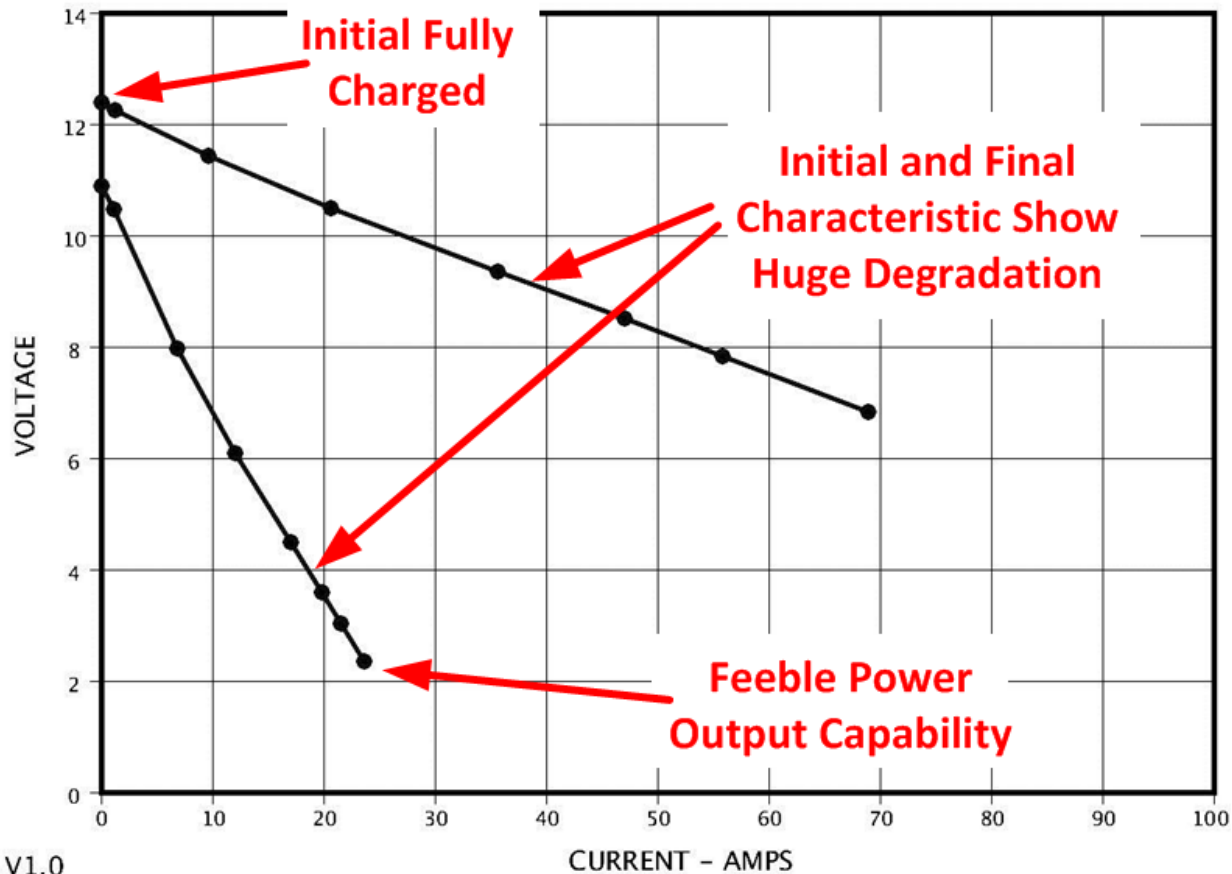

[Print Results](#)

Team 2619 Battery Test KIOSK V1.0



Ranking Criteria

- Max. Power Output after Simulation
 - Resiliency Results in Higher Value
- Battery Internal Resistance
 - Slope of the *Curve*
 - Non-Sagging Voltage Results in Lower Value
- Strong Negative Correlation
 - They are Related!



Performance Range of Batteries Tested

- 28 Batteries Were Tested
 - Five Different Manufacturers
 - Age Range 0 – 9 Years
 - Number of Charge Cycles Unknown
- All Indicated “Fully Charged”
 - Confirmed by Hand-Held Device
- Batteries Were Ranked by Performance Criteria

Data Analysis Spreadsheet

Battery ID	Year	Manufacturer	Mfg Type	Internal Res. Initial mΩ	Internal Res. Final mΩ	Internal Res. Rank	Final I _o	Final V _o	Final P _o (Watts)	Final P _o Rank	Average Rank
2017-10	2017	Duracell DURA12-18NB	1	14.86	14.80	1	103.76	10.43	1082.2	2	1.5
2017-9	2017	Duracell DURA12-18NB	1	15.62	15.20	2	104.42	10.52	1098.5	1	1.5
2017-7	2017	Duracell DURA12-18NB	1	16.19	15.74	4	103.32	10.41	1075.6	3	3.5
2016-2	2016	Power Patrol SLA1116	5	15.23	15.39	3	102.91	10.34	1064.1	5	4
2018-1	2018	Genesis NP18-12B	2	17.47	17.23	5	102.31	10.29	1052.8	6	5.5
2017-3	2017	Power Patrol SLA1116	5	17.95	18.15	9	103.35	10.38	1072.8	4	6.5
2016-3	2016	Genesis NP18-12B	2	17.92	17.90	7	102.19	10.27	1049.5	7	7
2018-2	2018	KEYO KT-12180 HRT GEL	3	19.94	18.14	8	101.40	10.19	1033.3	9	8.5
2014-2	2014	MKPowered ES17-12	4	17.30	18.43	10	100.96	10.12	1021.7	11	10.5
2017-2	2017	Power Patrol SLA1116	5	18.21	19.74	13	101.46	10.21	1035.9	8	10.5
2018-3	2018	KEYO KT-12180 HRT GEL	3	17.70	17.74	6	100.21	10.07	1009.1	15	10.5
2017-5	2017	Genesis NP18-12B	2	19.67	19.34	12	101.12	10.16	1027.4	10	11
2014-1	2014	Genesis NP18-12B	2	19.52	18.85	11	100.49	10.10	1014.9	13	12
2017-4	2017	Power Patrol SLA1116	5	19.11	19.89	15	100.62	10.07	1013.2	14	14.5
2017-6	2017	KEYO KT-12180 HRT	3	19.77	21.20	18	100.62	10.10	1016.3	12	15
2017-8	2017	KEYO KT-12180 HRT	3	19.70	19.76	14	99.92	10.00	999.2	17	15.5
2017-1	2017	Power Patrol SLA1116	5	19.77	19.97	16	100.02	10.05	1005.2	16	16
2014-3	2014	MKPowered ES17-12	4	22.02	20.86	17	97.35	9.74	948.2	19	18
2015-1	2015	Genesis NP18-12B	2	22.60	21.53	20	98.45	9.89	973.7	18	19
2014-4	2014	MKPowered ES17-12	4	22.14	21.28	19	94.43	9.47	894.3	22	20.5
2016-1	2016	Power Patrol SLA1116	5	24.44	21.89	21	96.47	9.68	933.8	20	20.5
2015-3	2015	Genesis NP18-12B	2	23.90	23.53	22	94.74	9.52	901.9	21	21.5
2015-2	2015	Genesis NP18-12B	2	22.78	24.48	24	94.36	9.45	891.7	23	23.5
2013-3	2013	Genesis NP18-12B	2	24.38	24.01	23	93.23	9.33	869.8	25	24
2012-4	2012	MKPowered ES17-12	4	23.35	26.04	25	93.74	9.41	882.1	24	24.5
2012-1	2012	Genesis NP18-12B	2	32.12	28.55	26	85.79	8.59	736.9	26	26
2009-1	2009	MKPowered ES17-12	4	27.62	34.98	27	72.50	7.22	523.5	27	27
2010-2	2010	MKPowered ES17-12	4	57.82	151.30	28	23.69	2.35	55.7	28	28

Data Analysis Graph

Power Output Range

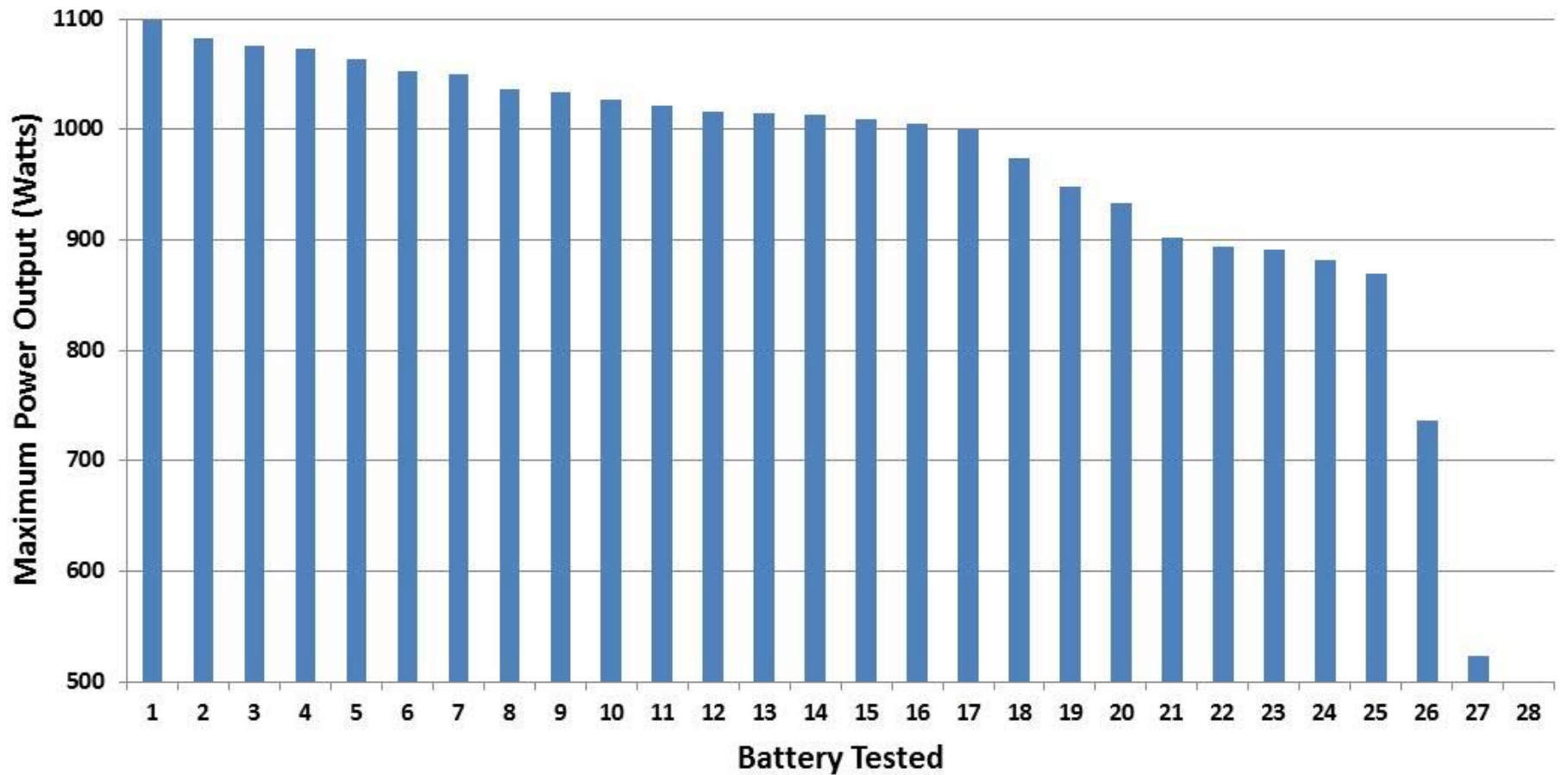

Other Interesting Outcomes

Maximum Power Output vs. Battery Age

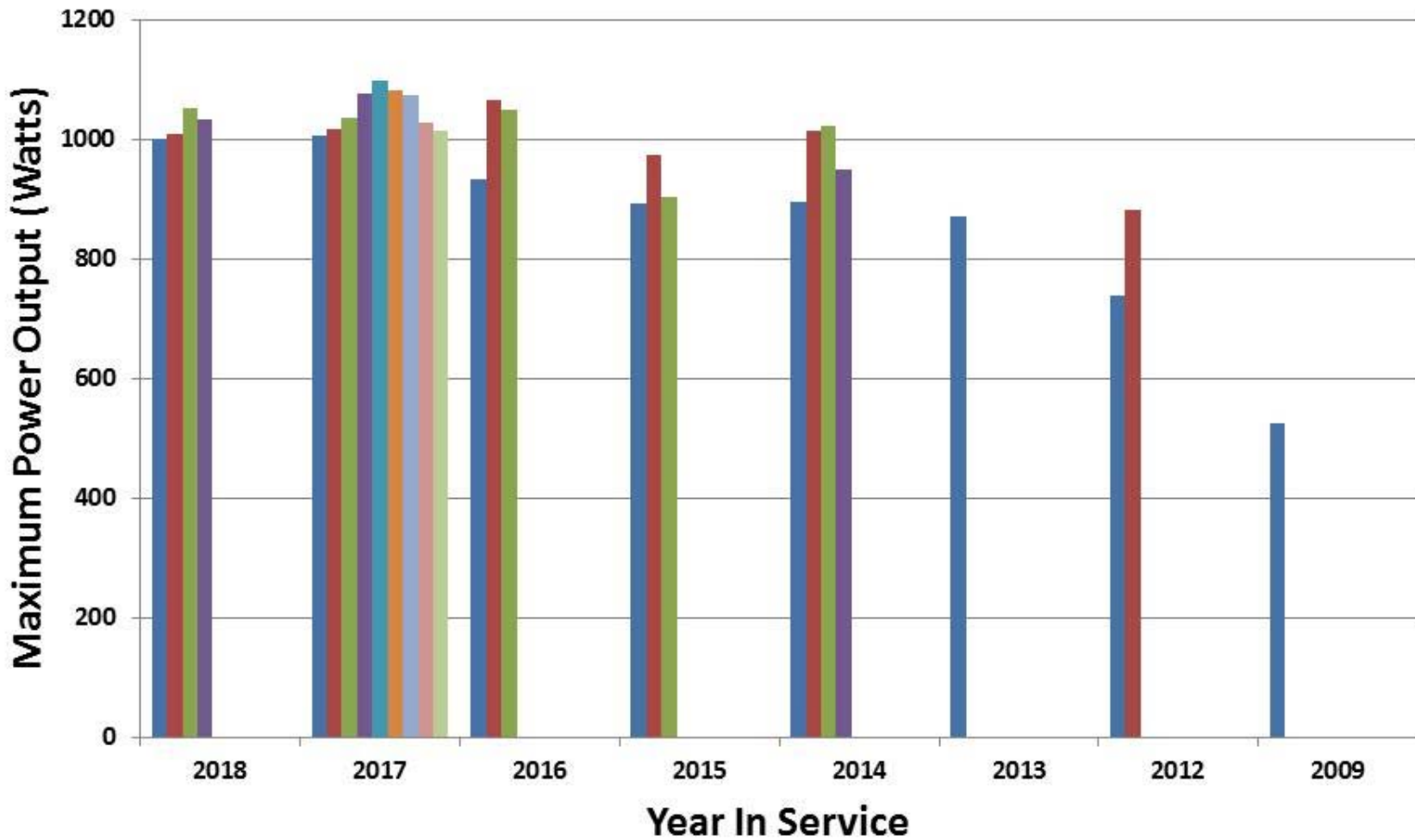

Other Interesting Outcomes

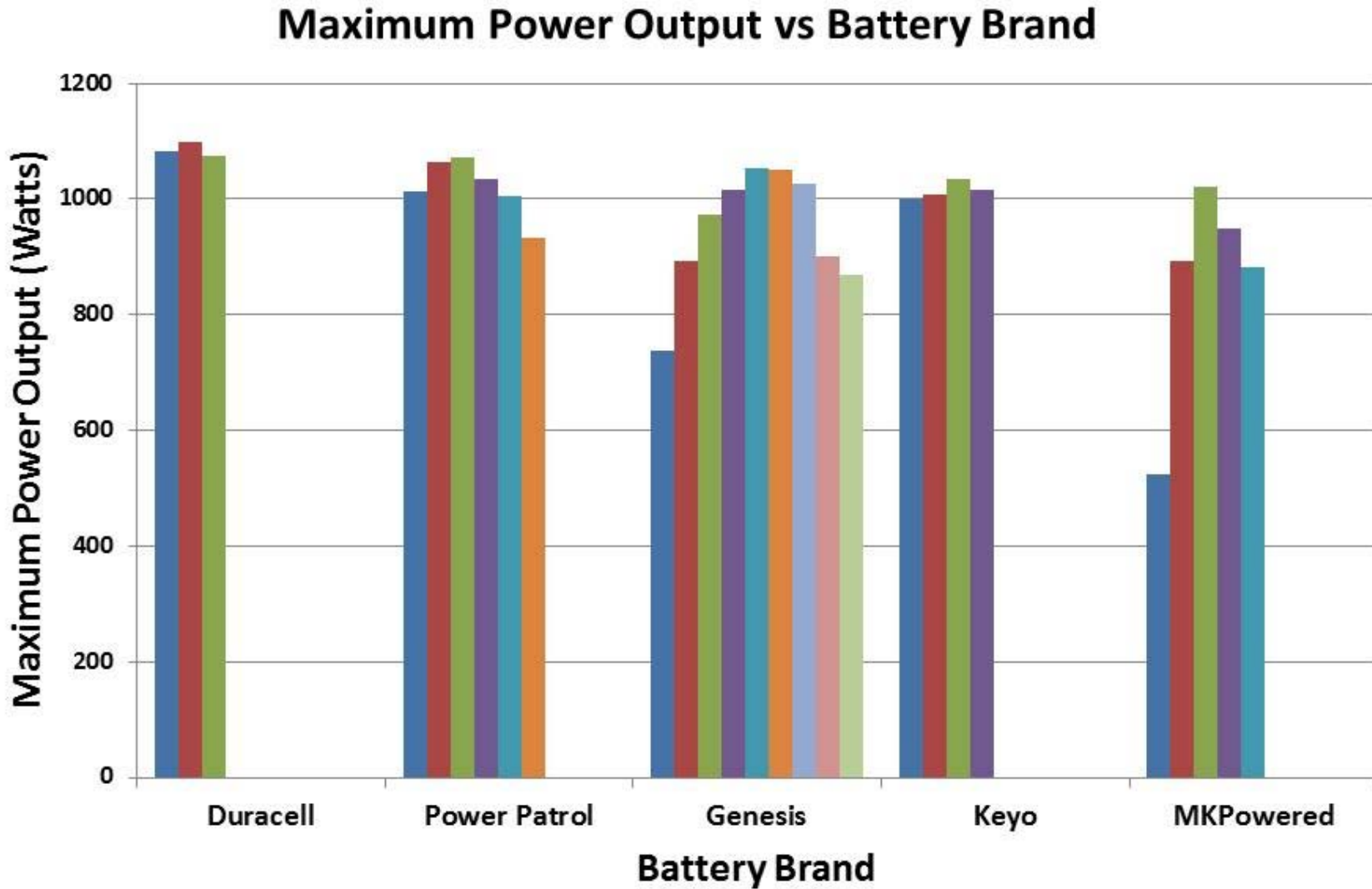



Improvements and Future Goals

- Logging Battery Charging Cycles
- Other FIRST Teams Building the Kiosk
- Collective Database for Battery Performance



Logging Battery Charging Cycles

- Outfit Each Battery With an RFID Tag
- Create a Mobile Application that a Pit Crew Uses to Track Charging Cycles
- Track Charging Cycles to Correlate with Battery Performance Curves

Mobile App Using RFID Technology

- An RFID Tag Affixed to each Battery
- An Application Could be Developed to Log the Battery Each Time it is Charged

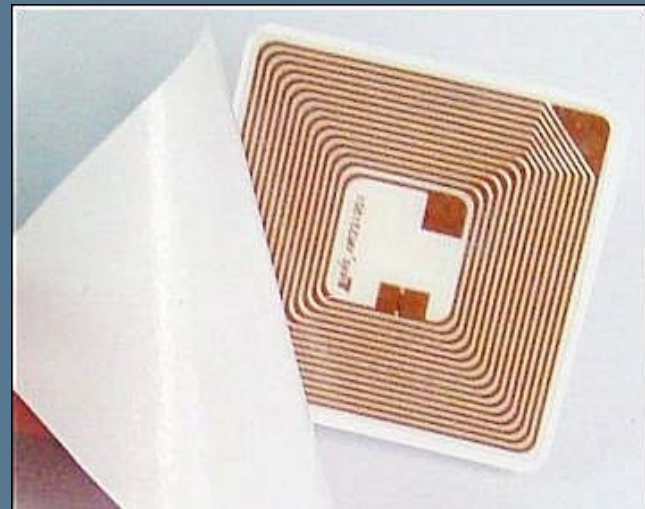



Other FIRST Teams Building a Kiosk

- Team 2619 Will Provide a Parts List and High Level Code for any Team That Wants to Build a Battery Test Kiosk
- Interested Teams Would be Able to Share Data
- Would Provide an Excellent Off-Season Project



Battery Test Kiosk Cost Breakdown

- A Total of 130 Individual Parts
- Majority of Cost in Power Resistors

Component / Assembly	Cost
Power Resistors	\$220
Power Supply Components	\$65
PC Board and Components	\$102
Software	\$0
Total Cost	\$387



Acknowledgements

- **Amelia Mylvaganam (Student – Team 2619)**
 - Data Analysis
 - Battery Testing
 - Video Demonstration Participant
- **Josh Kline (Student – Team 2619)**
 - Battery Testing
 - Battery Test Kiosk Cost Breakdown
- **Team 2619**
 - Unwavering Commitment to STEM
- **FIRST Robotics**
 - Opportunity to Present This Seminar

Conclusions / Q & A

- A 2-D Line Graph Characterization Curve Provides Insight in Battery Performance.

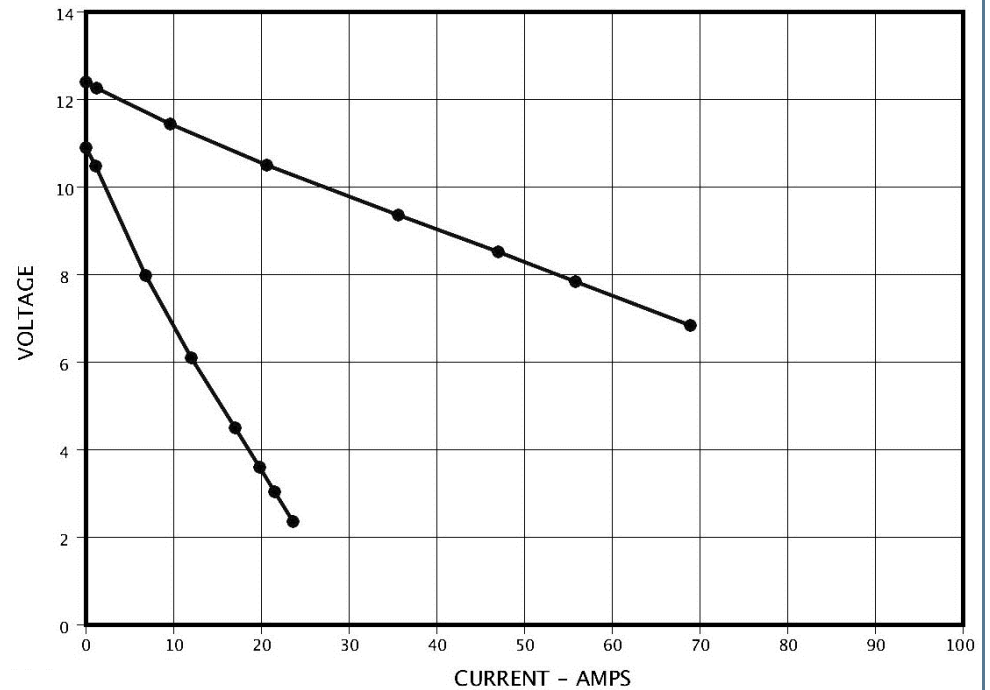
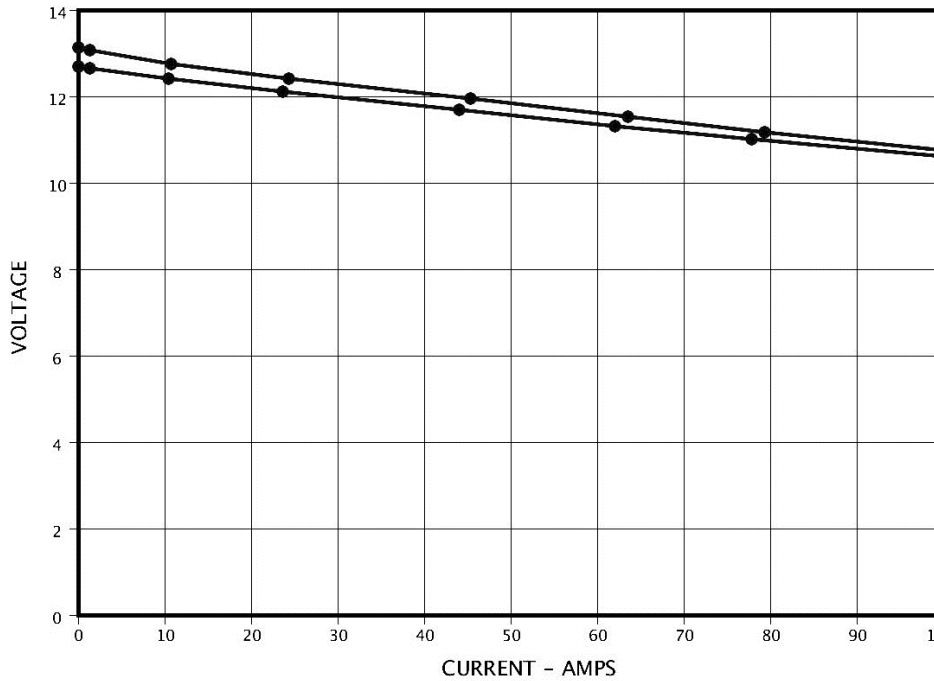



Conclusions / Q & A

- **A Match Simulator Allows a Battery to be Tested Without A Robot!**
- **Data Can be Stored and Shared.**
- **Other FIRST Teams Can Build the Kiosk.**
 - Sign Up Sheet After the Presentation
- **More Information in Our Battery Report:**
 - Download pdf at www.the-charge.com

Questions?

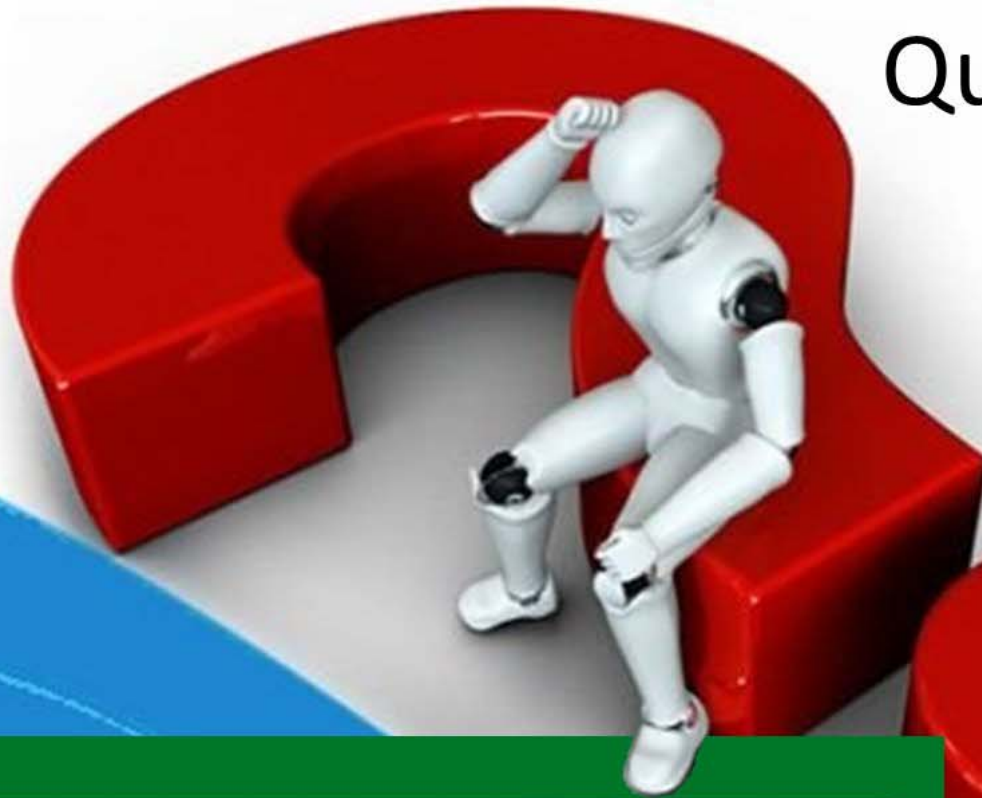

DOW HIGH'S
THE CHARGE
FIRST ROBOTICS TEAM FRC #2619

www.the-charge.com